

Technical Guide: EBE/EUE Upflow and Downflow Electric Furnace

BHC Group Heating & Cooling, 5005 York
Drive, Norman, OK 73069

6601749-BTG-A-1025
Supersedes: 5417543-BTG-F-0824

2025-10-02

Contents

Certification.....	3
Description.....	3
Warranty.....	3
Features.....	3
Physical and electrical data.....	4
EBE/EUE series blower performance.....	5
Wiring requirements.....	6
Location.....	6
Furnace clearance.....	6
Return air.....	7
For heating only furnace.....	7
For 5 ton AC applications (accessory blower).....	7
Return air location.....	7
Air filter.....	7
Filter location.....	7
Third-party trademarks.....	9

Certification

Assembled at a facility with an ISO 9001:2015-certified Quality Management System



Description

The EBE/EUE Series Electric Furnace is actually two systems in one - an air handler and an electric furnace. As an air handler, it provides airflow for air conditioning and heat pump cooling requirements. As an electric furnace, its range of heating capacities makes the EBE/EUE a perfect match for the heating requirements of almost any manufactured or modular home.

Warranty

2-year limited parts warranty, and 1-year labor.

Features

- Zero clearance feature allows the EBE/EUE unit to be installed where space is a premium.
- Pre-painted white front panels provide a scratch resistant, attractive, easy to clean appliance finish.
- Built-in coil cabinet is design-matched to work in conjunction with EBE/EUE furnaces, heat pumps, and air conditioners manufactured by BHC Group Heating & Cooling, providing ease of installation and highly efficient operating performance. The EBE/EUE unit has a coil shelf installed. The EBE unit has a louvered door and the EUE unit has a solid door.
- Air Conditioner and Heat Pump operation ready. All models have a multi-speed blower capable of handling cooling and heat pump loads.
- Heating package includes specifically designed, long lasting nickel/chrome heat elements.
- Universal throw-away filter cleans the air and is easy to replace on the EBE unit. No filters are furnished with EUE models. External filter base and/or filter rack needed for field installation.
- Accessory blower kit available for larger A/C applications.
- As defined by the U.S. Department of Energy, these furnaces are 100% efficient when used in specified applications.

Physical and electrical data

Figure 1: Dimensions

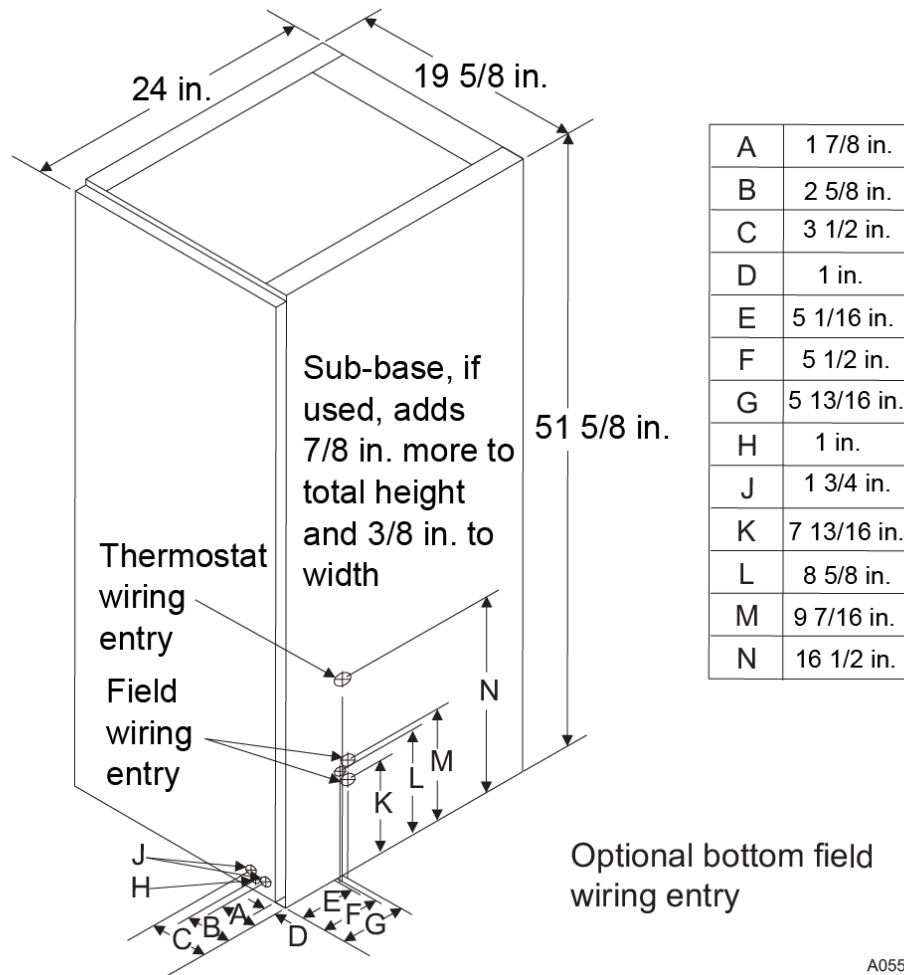

A0552-002

Table 1: Physical and electrical data

Model number			^{2,3} EBE10*	^{3,4} EBE12*	⁵ EBE15*	⁵ EBE17*	⁵ EBE20*	⁵ EBE23*
			EUE10*		EUE15*		EUE20*	
D.O.E. output	240 VAC 60 Hz, 1 Phase	BTU	34,000	39,000	51,000	56,000	67,000	77,000
		kW	10.0	11.4	15.0	16.4	19.6	22.6
Output capacity	230VAC 60Hz, 1 Phase	BTU	31,000	36,000	47,000	52,000	61,000	71,000
		kW	9.1	10.6	13.8	15.2	17.9	20.8
	208VAC 60Hz, 1 Phase	BTU	25,500	29,250	38,250	42,000	50,250	57,750
		kW	7.5	8.6	11.3	12.3	14.7	17.0
Element capacity @ 240 VAC		kW	9.6	11.2	14.4	16.0	19.2	21.6
		Amps	40.0	46.7	60.0	66.7	80.0	90.0
Motor Amps @ 240 V			4.0 Maximum					

Table 1: Physical and electrical data

Model number		^{2,3} EBE10*	^{3,4} EBE12*	⁵ EBE15*	⁵ EBE17*	⁵ EBE20*	⁵ EBE23*
		EUE10*		EUE15*		EUE20*	
Circuit load Amps @ 240 V	CKT 1	43.8	50.5 ⁵	43.8	47.1	43.8	47.1
	CKT 2	n/a	n/a	20.0	23.3	40.0	46.7
Filter size for EBE in top of unit only - in.		16 x 20 x 1					
Filter size for EBE in louvered door only - in.		20 x 20 x 1					
Shipping weights		83	84	85	86	84	86

① Note:

1. Casing or cabinet must be permanently grounded in accordance with National Electrical Code (NEC) or other applicable codes.
2. Does not require a jumper.
3. Approved for single branch circuit service only.
4. Jumper provided for single branch circuit only.
5. Jumper bar is required for single branch circuit connection (P/N 3500-378P).

EBE/EUE series blower performance

Table 2: Blower performance

Static pressure (in. W.C.)	Speed	0.1	0.2	0.3	0.4	0.5	0.6	0.7	0.8
		CFM (STD. Air) for all EBE/EUE models	High (5)	1375	1350	1325	1275	1250	1225
	Medium High (4)	1225	1175	1150	1125	1100	1050	1025	1000
	Medium (3)	1075	1025	1000	950	925	875	850	800
	Medium Low (2)	950	925	900	875	850	800	750	725
	Low (1)	600	575	525	500	475	450	425	375

① Note:

Applications with static pressures higher than 0.3 in. are not recommended.

A blower off delay of 60 seconds is built into the motor.

For up to E(B,U)E15* models heating, use Medium Low speed (2) for compliance with Fan Efficiency Rating test.

For EBE17*, E(B,U)E20* and EBE23* models heating, use Medium speed (3) for compliance with Fan Efficiency Rating test.

For all models constant fan operation, use Low speed (1) for compliance with Fan Efficiency Rating test.

Wiring requirements

Table 3: Wiring requirements for EBE/EUE

Models	¹ EBE10* EUE10*	² EBE12*	³ EBE15* EUE15*		³ EBE17*		³ EBE20* EUE20*		³ EBE23*	
Single branch circuit service	2 Leads + 1 Ground CKT #1									
Nominal circuit load - Amps	43.8	50.5	63.8		70.4		83.8		93.8	
Minimum wire size (90°C)	#8	#6	#4		#4		#3		#2	
Minimum wire size (75°C)	#6	#6	#4		#3		#2		#1	
Minimum wire size (60°C)	#6	#4	#3		#2		#1		#0	
Ground wire size	#10	#8	#8		#8		#6		#6	
Max. fuse (or C.B.) - Amps	60	70	80		90		110		125	
Dual branch circuit service	Not approved		CKT #1	CKT #2	CKT #1	CKT #2	CKT #1	CKT #2	CKT #1	CKT #2
Branch circuit load - Amps			43.8	20.0	47.1	23.3	43.8	40.0	47.1	46.7
Branch circuit min. - Amps			54.8	25.0	58.9	29.1	54.8	50.0	58.9	58.4
Minimum wire size (90°C)			#8	#10	#6	#10	#8	#8	#6	#6
Minimum wire size (75°C)			#6	#10	#6	#10	#6	#8	#6	#6
Minimum wire size (60°C)			#6	#10	#4	#10	#6	#6	#4	#4
Ground wire size ⁴			#10	#10	#10	#10	#10	#10	#10	#10
Max. fuse (or C.B.) - Amps			60	30	60	30	60	50	60	60

ⓘ Note:

1. Does not require a jumper.
2. Jumper provided for single branch circuit only.
3. Jumper bar is required for single branch circuit connection (P/N 3500-378P).
4. Refer to NEC. Table 250-122 for Non-Sheathed Conductor Ground Wire.

Location

Access for servicing is an important factor in the location of any furnace. A minimum of 24 in. must be provided in front of the furnace for access to the heating elements and controls. This access can be provided by a closet door or by locating the furnace 24 in. from a facing wall or partition.

Furnace clearance

This furnace is approved for 0 in. clearance to combustible material on all or any part of the furnace exterior and the inlet or outlet duct work except as stated below.

For furnaces installed in upflow application, there must be a minimum of 1 in. (2.54 cm) clearance from the bare surface of the outlet duct work for a distance of 3 ft (91.4 cm) from the supply air opening. This requirement is met if the duct is wrapped with an insulating material at least 1 in. thick that has an R-value of at least R-4.

Return air

In order for the furnace to work correctly, a closet or alcove must have a certain total free area opening for return air.

For heating only furnace

A minimum of 200 sq in. (1290 sq cm) free area opening. Use any return grille with a minimum of 200 sq in. free opening.

For 5 ton AC applications (accessory blower)

A minimum of 350 sq in. (2129 sq cm) free area opening. Use 5 ton AC blower accessory 3500-7911. Use any return grille with a minimum of 350 sq in. (2129 sq cm) free area opening with 5 ton AC blower accessory 3500-7911. The upflow return air box accessory 3500-8982 can also be used with 5 ton AC blower accessory 3500-7911.

Return air location

For downflow applications, the return air opening can be located in a closet front door, in a sidewall above the furnace casing, or in a louvered door on the furnace. If the opening for the return air is located in the floor, sidewalls, or closet door anywhere below the furnace casing height, 6 in. minimum clearance must be provided on the furnace side where return is located to provide for proper airflow.

For upflow installations, a closet that is 32 in. wide by 30 in. deep with a 30 in. wide door is necessary. This is not required if there is a return grille installed below the furnace.

Air filter

The filter supplied with the furnace is a throw-away filter. Filters need to be cleaned frequently. The filter supplied with the furnace is disposable and not reusable. Change filters often because clean filters provide added comfort, provide a better and cleaner environment, and increase the efficiency of the furnace.

Filter location

The front panel of the furnace must be removed to gain access to the filter of the downflow furnace. However, the filter for the upflow furnace is located behind the return air grill, adjacent to the furnace closet or any other location in the return air.

Figure 2: Downflow application

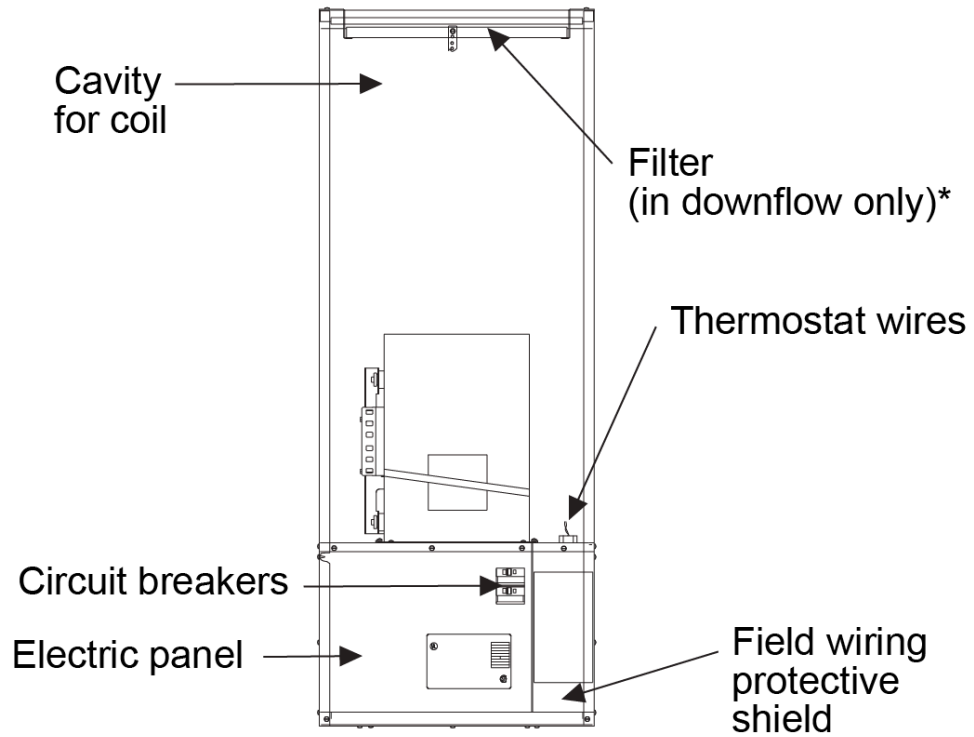

*Filter in the front panel when louvered doors are used.

Downflow application

A0864-002

Figure 3: Upflow application

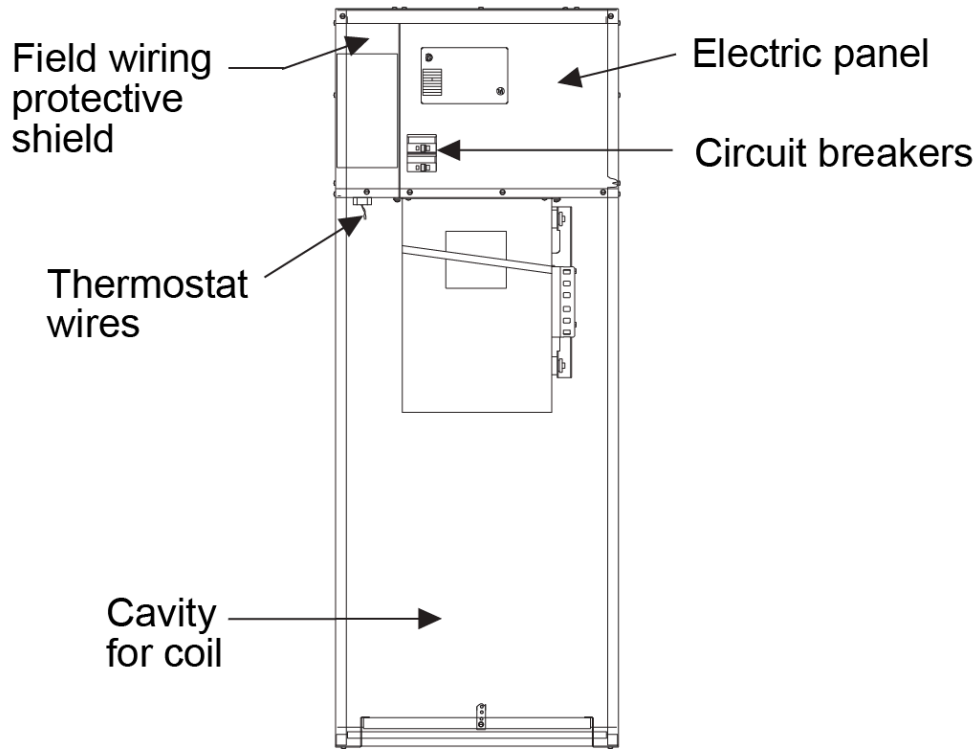

Note: Filter located in base for upflow box below unit.

Upflow application

A0865-002

Third-party trademarks

Third-Party Trademarks Notice: For information about third-party trademarks, refer to the relevant company websites.